

E5205.2  
INOX BOTTOM SUPPORT  
FOR OLYMPIC PLATFORM

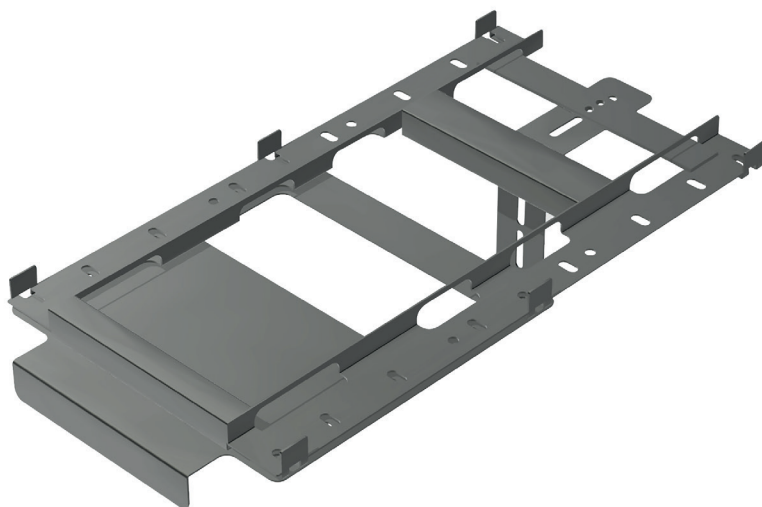





MI.E5205.2.EN - 20012022





**INSTRUCTION MANUAL**

## WARNING

Failure to follow these warnings and installation instructions may result in serious injury. Please read the instructions carefully before installing your equipment.  
Keep these instructions. DO NOT DISCARD.

## PACKAGE CONTENT

	A	1x Support Structure
	B	1x Rear adjustment in L
	C	2x Stainless Steel Washer M8mm A4 DIN 125 A
	C1	4x Special Washer M8
	D	1x Nylon Washer 40mm

	E	2x Stainless Steel Screw M8x100mm A4 DIN 933
	F	6x Stainless Steel Screw M8x40mm A4 DIN 7991
	G	1x Stainless Steel Screw M8x40mm A4 DIN 933
	H	2x Stainless Steel Screw M8x60mm A4 DIN 933
	I	1x Stainless Steel Nut M8mm A4 DIN 315
	J	6x Stainless Steel Nut M8mm A4 DIN 934
	L	4x Stainless Steel Nut M8mm A4 DIN 985

# INSTALLATION

## FIXING OPTION 1

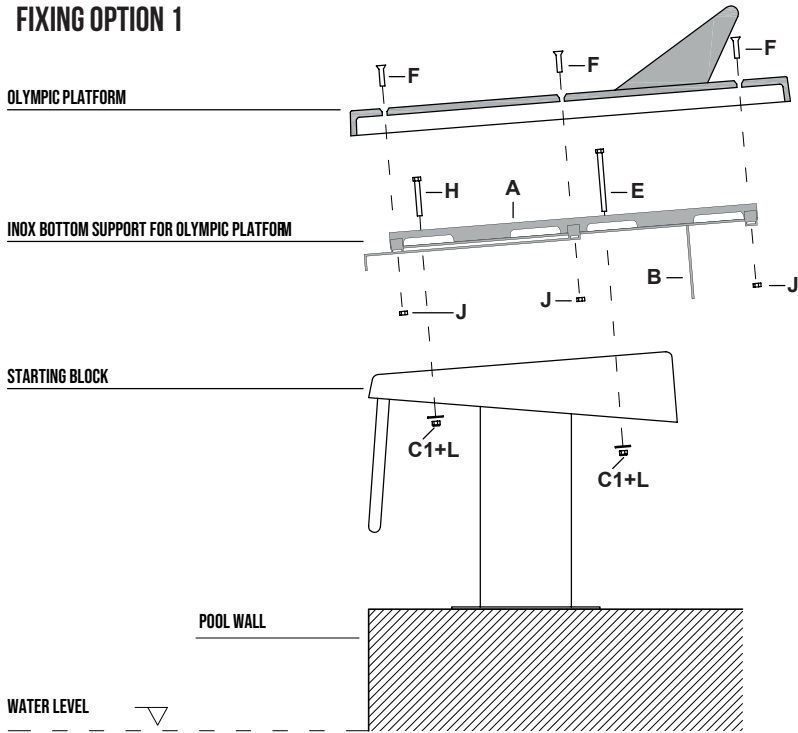

1. Screw part **B** to part **A** using 1x **G** + 2x **C** + 1x **D** + 1x **I**.
2. Align and center the bottom support on top of the starting block, lean the front part and tighten part **B** so that the bottom support is in its final position.
3. Drill 4 holes in the jump platform through the holes already existing in the bottom support. Apply 2x **E** in the rear drillings, and 2x **H** in the front, screwing 4x **C1**+ 4x **L**.
4. Place 6x **J** in the slots.
5. Position the olympic platform on top of the support, align and slightly tighten 6x **F**. Then tighten from the middle to the ends.

1



2

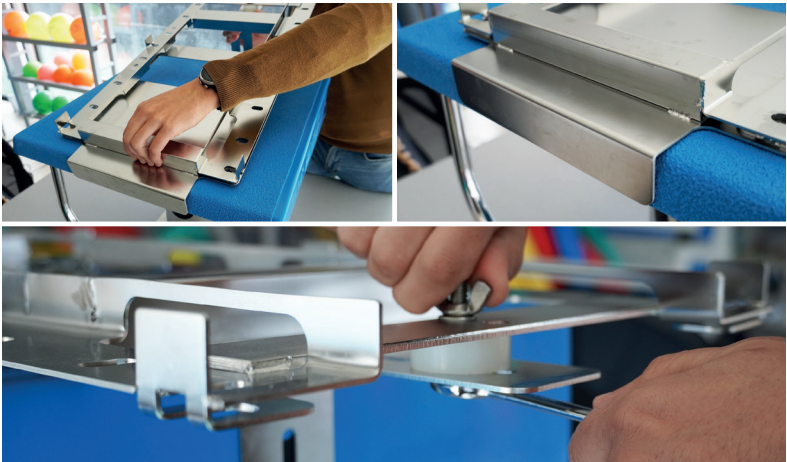

3



4

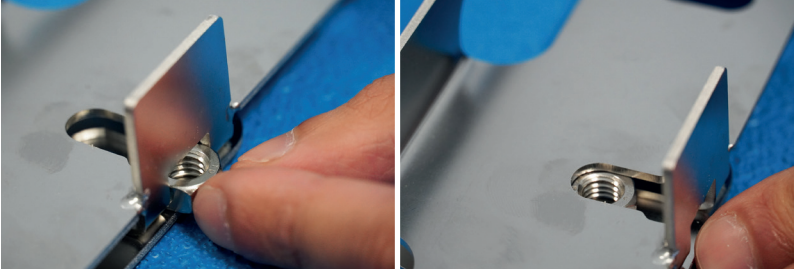

5

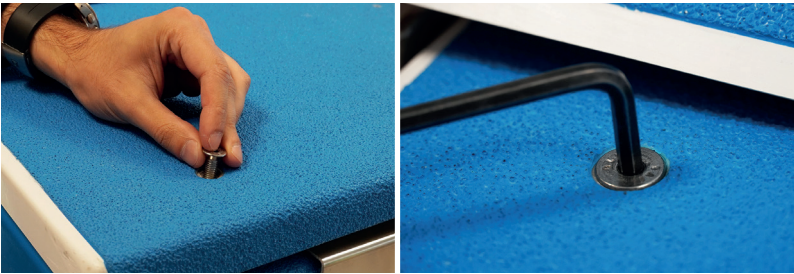

# INSTALLATION

## FIXING OPTION 2

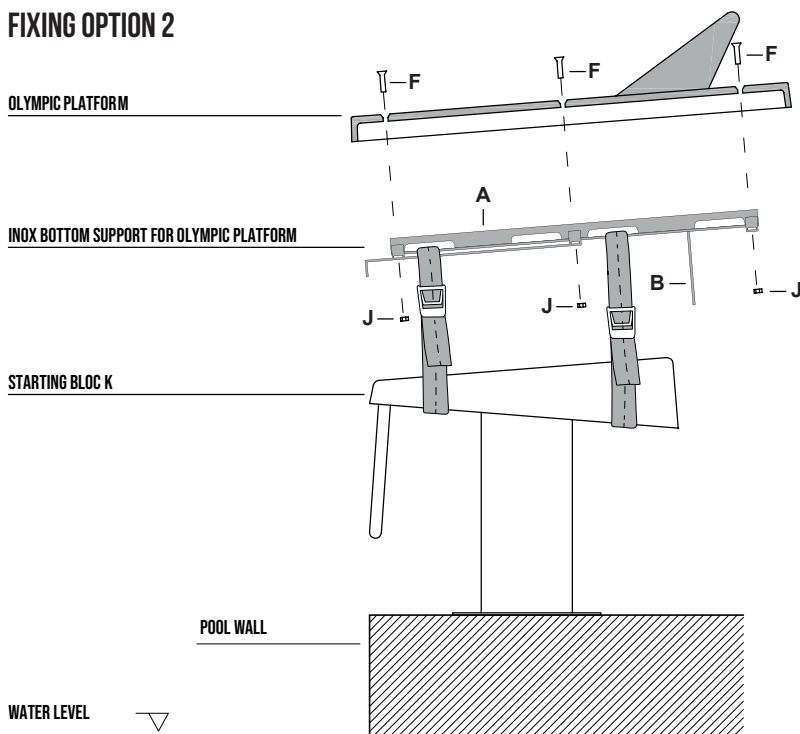

1. Screw part **B** to part **A** using 1x **G** + 2x **C** + 1x **D** + 1x **I**.
2. Align and center the bottom support on top of the starting block, lean the front part and tighten part **B** so that the bottom support is in its final position.
3. Pass the straps (not supplied) through the openings in the support and tighten them.
4. Place 6x **J** in the slots.
5. Position the olympic platform on top of the support, align and slightly tighten 6x **F**. Then tighten from the middle to the ends.

1

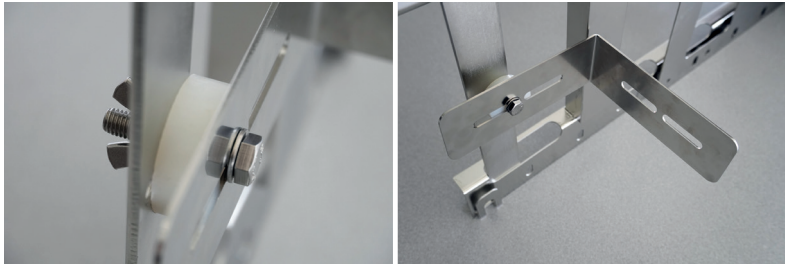

2

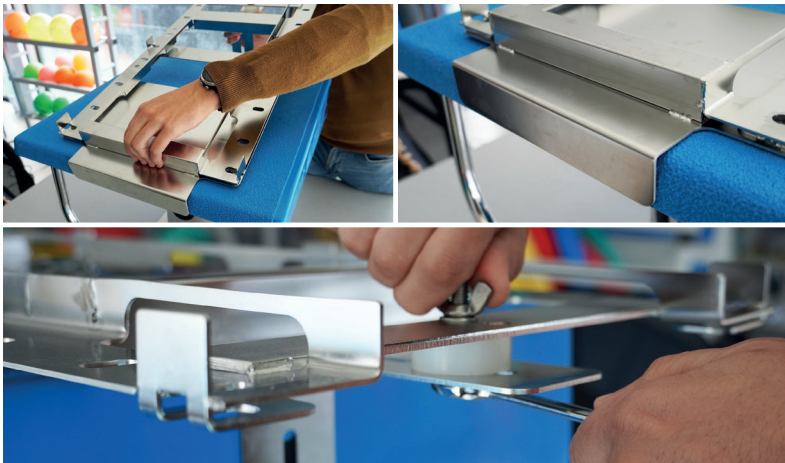

3



**WARNING! Excessive tightness can lead to platform breakage.**



4

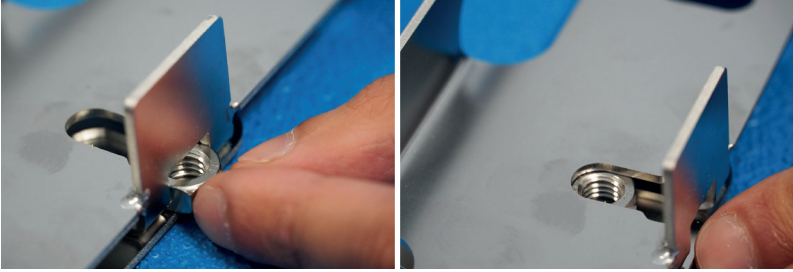

5

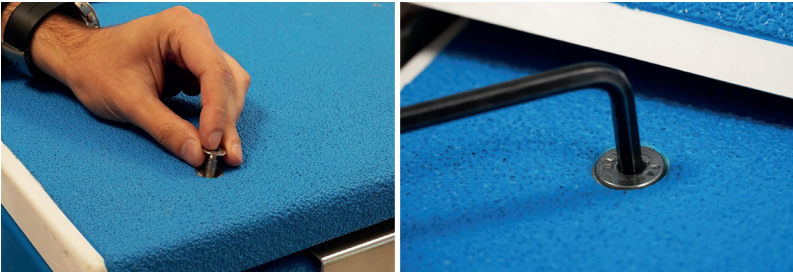

 **WARNING**

**VFA LTD IS NOT RESPONSIBLE FOR ANY ACCIDENT OR ANY DAMAGE RESULTING FROM THE INAPPROPRIATE USE OF OUR PRODUCT OR EQUIPMENT.**